



The installation must only be performed by a licensed electrician.
L'installation ne doit être effectuée que par un électricien agréé.

To prevent death, injury or damage to property, this product must be installed in accordance to National Electric Code (NFPA70) in the US or Canadian Electrical Code (CSA22.1) in Canada.
Pour prévenir les décès, les blessures ou les dommages matériels, ce produit doit être installé conformément au Code national de l'électricité (NFPA70) aux USA ou Code Canadien de l'Électricité (CSA22.1) au Caada.

Disconnect power before installing the product or servicing it.
Débranchez l'alimentation avant d'installer ou de le réparer le produit.

Wait until fixture has cooled don before installing or servicing the fixture.
Attendre jusqu'à ce luminaire soit refroidi avant l'installation ou l'entretien du luminaire.

Min 105°C Supply Conductors - *LES FILS D'ALIMENTATION 105°C MIN*
Rated Ambient 40C – Évalué Ambient 40C Ambiance nominale 40C
Suitable for damp locations - Convient aux emplacements humides

CAUTION

- This LED lighting fixture must be installed above the target surface with the light targeted downward, protecting the electrical components from moisture and debris. **DO NOT install with the light source facing upward.**
- If two power sources are required, then wire power to the fixture through the left and right endcaps. **DO NOT make the power connection at the midpoint of the luminaire.**

Component List

Part number	Description
SKT1-1-XX-XX-XX-1-XX-XX-L	Linear Star luminaire, 1 ft, Left End unit
SKT1-1-XX-XX-XX-1-XX-XX-R	Linear Star luminaire, 1 ft, Right End unit
SKT1-1-XX-XX-XX-4-XX-XX-L	Linear Star luminaire, 4 ft, Left End unit
SKT1-1-XX-XX-XX-4-XX-XX-R	Linear Star luminaire, 4 ft, Right End unit
SKT1-1-XX-XX-XX-4-XX-XX-C	Linear Star luminaire, 4 ft, Center unit
SKT1-1-XX-XX-XX-4-XX-XX-S	Linear Star luminaire, 4 ft, Stand Alone unit
SMT1-1-XX-27*	Mount Arm, 27° fixed angle, 2 – 4 ft tall sign
SMT1-1-XX-22*	Mount Arm, 22° fixed angle, 4 – 6 ft tall sign
SMT1-1-XX-18*	Mount Arm, 18° fixed angle, 6 – 8 ft tall sign
SMT1-1-XX-V*	Mount Arm, variable angle, 2 – 8 ft tall sign
PSH1-1-A-O-X-4	LED Driver, 100W, 24V, Class 2, outdoor rated
PSC1-1-B-XX	Power cable, outdoor rated

*Note: Only one of the Mount Arm types is needed for an installation. The type depends on the sign height as illustrated in the next section.

Fixture Installation

Fixture Mount Spacing and Head Angle

Figure 1 shows a mounting diagram for Linear Star. Note the location of the fixture relative to the sign surface. The Head Angle is critical to achieve uniform lighting on the sign surface and depends on the sign height as shown in Table 1.

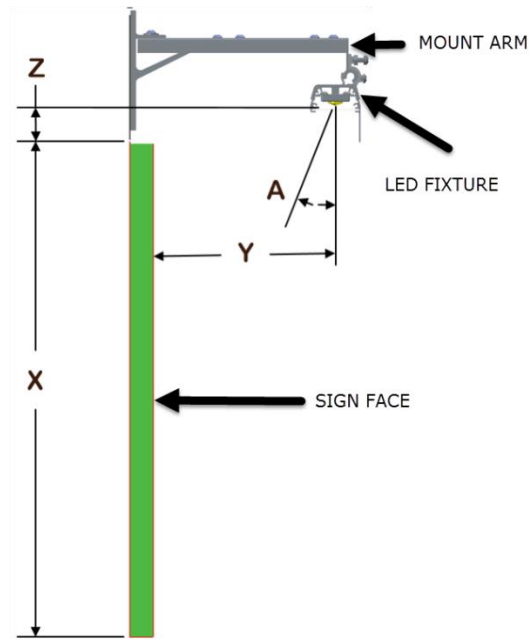

Figure 1: Mounting Diagram

Table 1: Table of Distances

Sign / Wall Height (X)	Distance to Target Surface (Y) **	Mount Offset (Z)	Head Angle (A)
2' to less than 4'	15"	7"	27°
4' to less than 6'	15"	7"	22°
6' to 8'	15"	7"	18°
2' to 8'	15"	7"	18° - 27° *

* It is critical that the angle be set for best projection of light onto the sign. If the angle is not properly set then the light might not be projected at the extremities of the sign's height.

** Keep the LED Fixture approximately 15" from the sign face by mounting it at the appropriate location on the Mount Arm.

A fixture assembly consists of a Left Unit, Right Unit and several Center Units depending on the desired total fixture length. The fixture length can range from 4 to 50 ft in increments of 2-ft. Figure 2 shows the basic configuration of the fixture assembly for various length configurations.

Interconnecting Fixtures

1. Fixtures are interlinked with a Mount Bracket as shown in Figure 3. The Mount Bracket is pre-installed onto the fixture. To connect to the adjacent fixture simply attach the open end of the Mount Bracket to the adjacent fixture and secure it with the two #8-32X1/4" thread cutting screws provided.
2. Connect the wires located under the Mount Bracket. Connect red to red, blue to blue and yellow to yellow. The yellow wire is only required if the dimming feature of the fixture is used. Trim or cap the yellow wire if dimming is not used (see Figure 5).
3. Secure the Wire Guard with the 2 provided #4-24X3/8" flat head screws (Figure 3).
4. It is recommended to assemble and mount fixture assemblies longer than 12 feet in sections.
5. See Figure 4 to mount end units.

Mount Arm Installation

1. Each Mount Bracket has an associated Mount Arm.
2. Refer to Figure 2 for the spacing between adjacent Mount Arms. Note that the spacing between Mount Arms is not always the same (34", 41", or 48").
3. Secure Mount Arms with 4 bolts per arm (not provided). The mounts must be securely mounted to the structure with proper backing. This will vary depending on the installation site requirements.

Connecting the Fixture Assembly to the Mount Arms

1. The LED Fixture must be located roughly 15" from the sign face. Adjust the Mount Bracket along the Mount Arm if needed to accomplish this. The swivel on the Mount Bracket is pre-installed at a 21" distance from the wall, which is good for a 6" deep sign. See Figure 1.
2. Slide the Fixture Assembly onto its associated Mount Arm as shown in Figure 6.
3. Use the included #8-32 x 1/4" Thread Cutting screws to contain the Swivel within the Mount Bracket (see Figure 7).

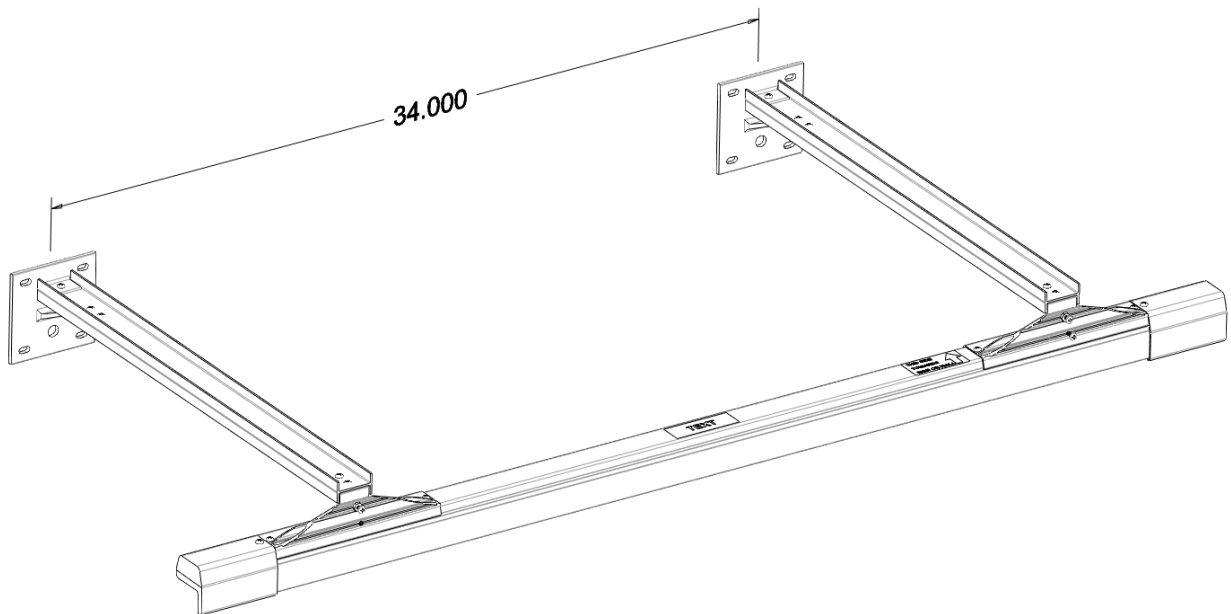

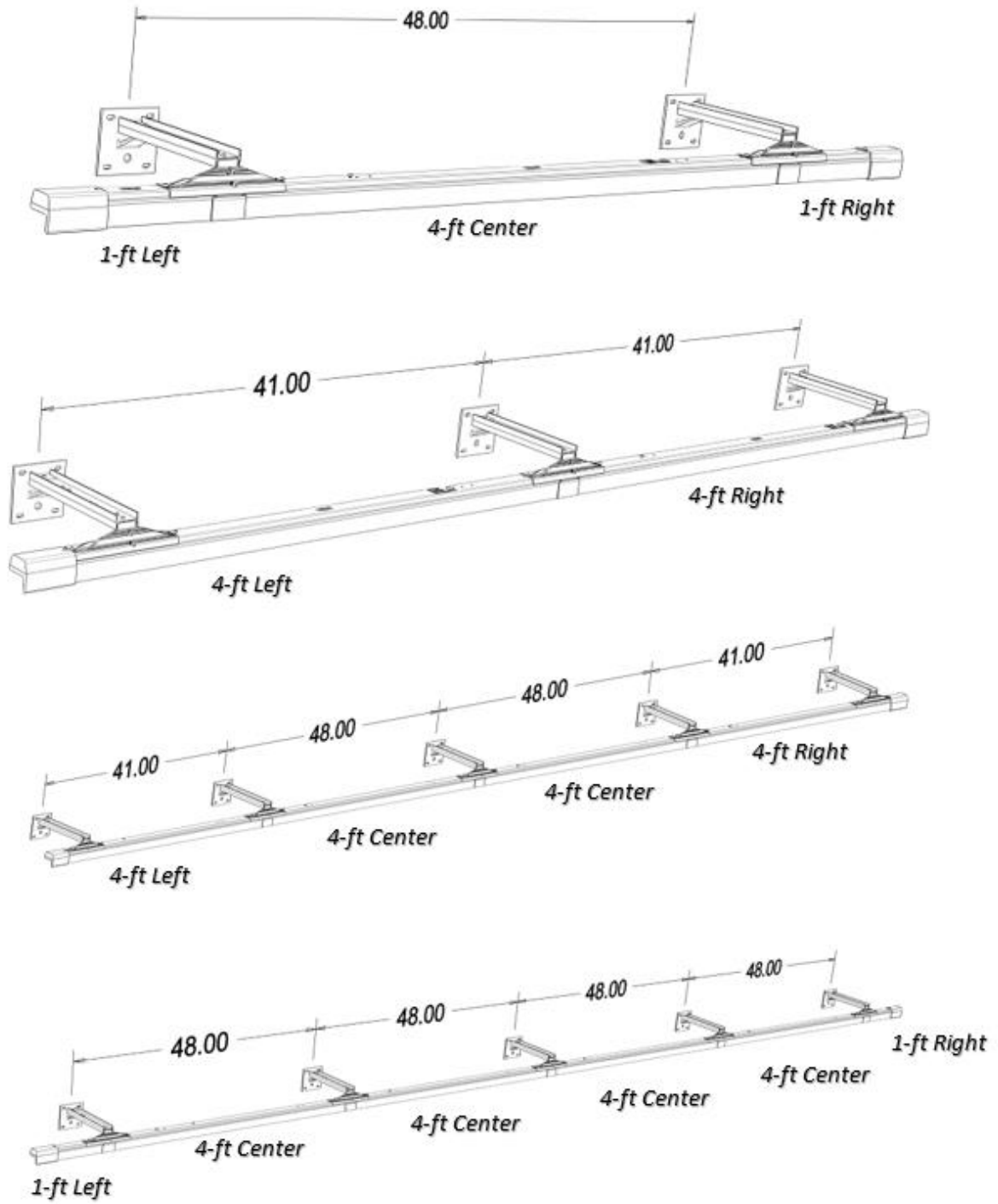

Figure 2: Left, Center and Right mount assemblies for various fixture lengths.

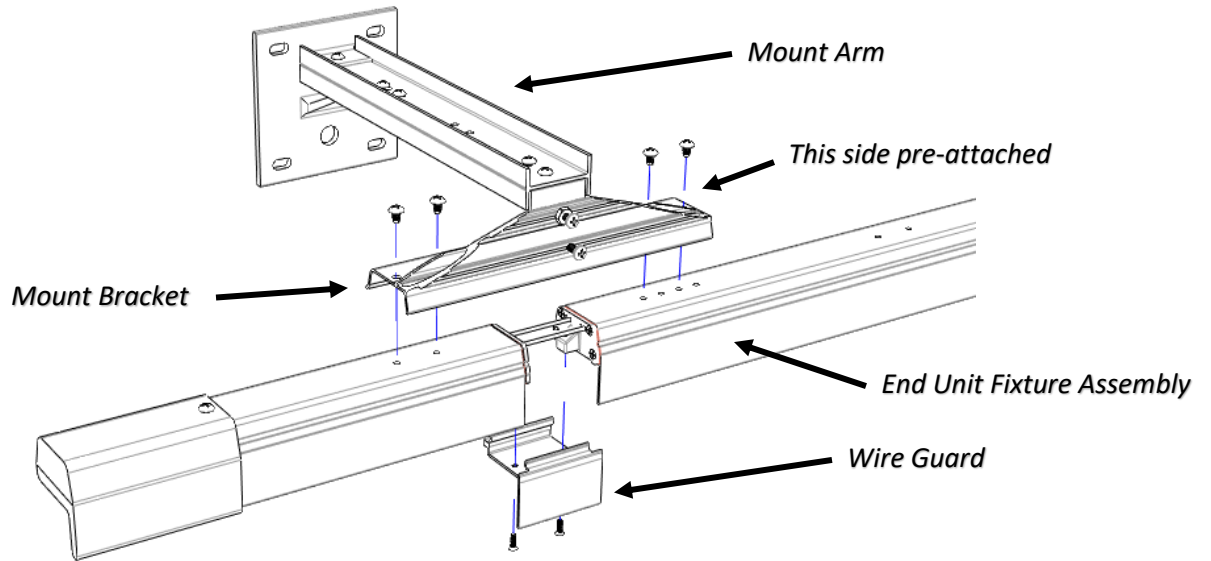

Figure 3: Connecting to a 1 ft End-to-Center units or Center-to-Center units. Note that the Mount Bracket straddles 2 fixtures.

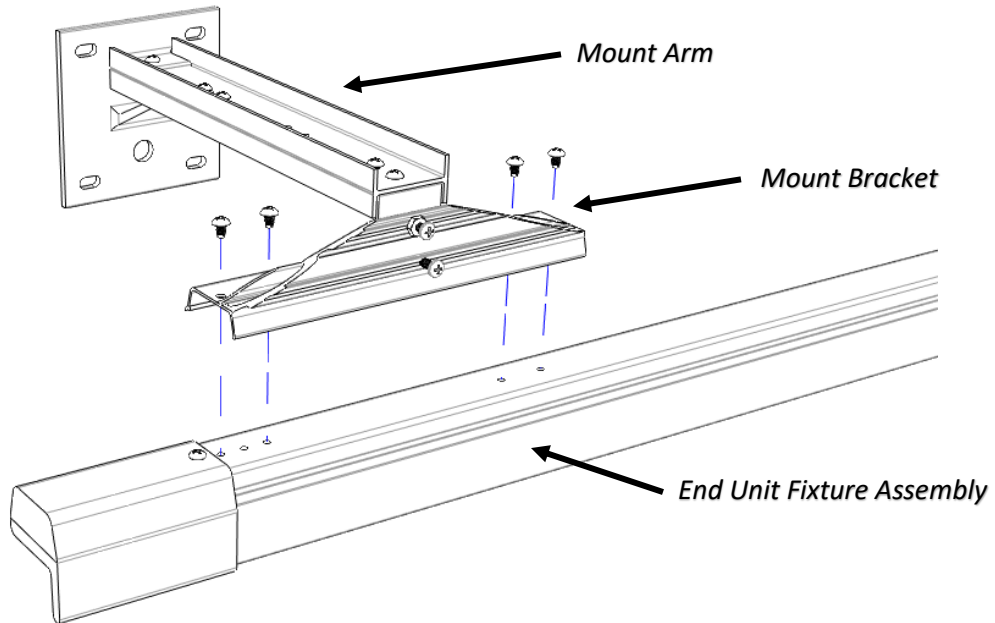

Figure 4: Connecting to a 4-ft End unit.

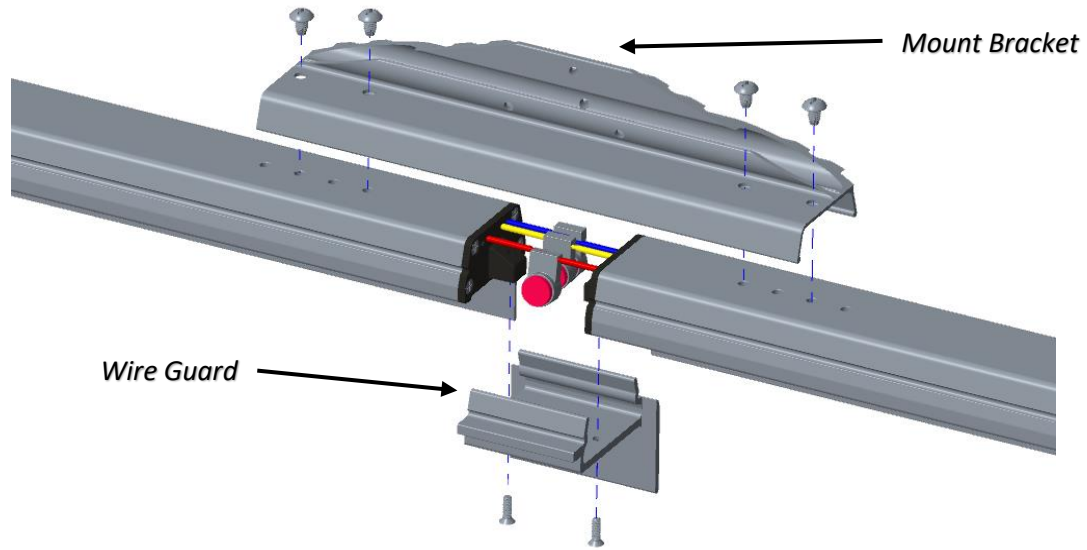

Figure 5: Electrically connecting adjacent fixtures.

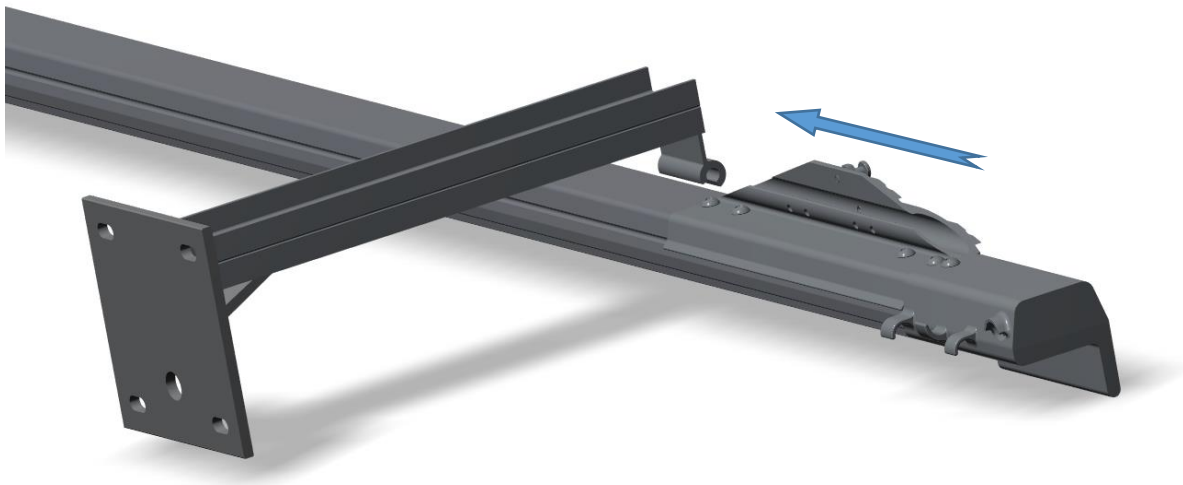

Figure 6: Slide fixture on the Mount Arm

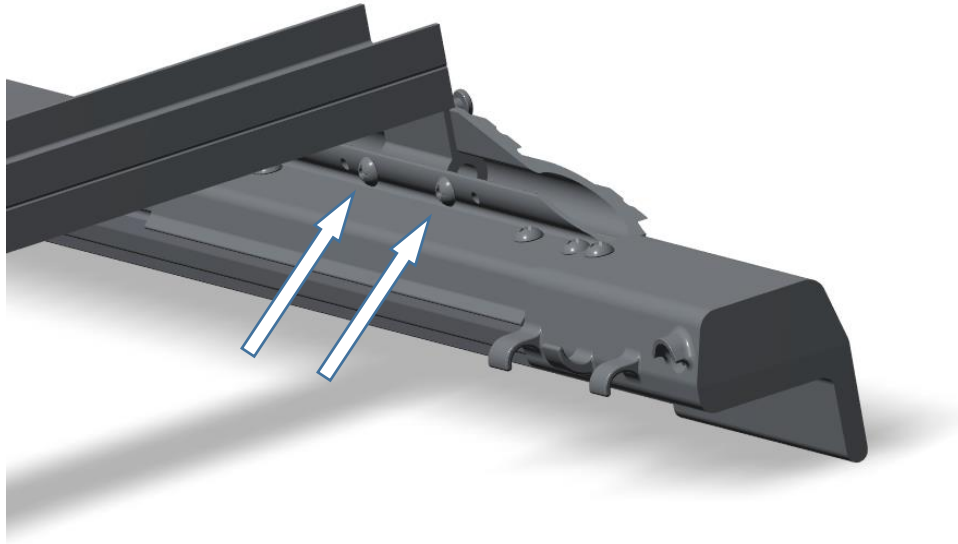

Figure 7: Secure fixture from sliding movement by tightening the containment screws

Running Power to Fixture

1. Power is supplied to the fixture by running power cabling to the end cap(s). The number of drivers and cables are determined by the fixture's power rating and total assembled length. See the section about LED Driver Loading for details.
2. Remove the endcap that will host the power connection (see Figure 9).
3. Run the power cable through the hole in the end cap. Connect the red or white wire of the power cable to the red wire of the fixture. Connect the black or blue wire of the power cable to the blue wire of the fixture. If a dimming yellow wire is provided in the power cable, then connect it to the yellow wire of the fixture.
4. Replace the endcap and secure it with its screw. Route the power cable along the fixture utilizing the cable management features molded into the endcap (see Figure 10). Route the cable along the Mount Arm by securing it to the arm using P-clips or cable ties (not provided).
5. Wire the power cable to the secondary side of the LED driver. Connect the red wire of the LED driver to the red or white wire of the power cable. Connect the blue wire of the LED driver to the blue or black wire of the cable.

Set the Head Angle

This step is only required if the Variable Angle Mount Arm (part number SMT1-1-XX-V) is used.

1. After connecting the fixture assembly to the mount arms, some adjustment is required when using the variable angle mount arm. See Figure 8.
2. This adjustment can be done either for each section or after all sections are in place.
3. The goal is to aim the light so that the entire sign is lit. Pay particular attention to aiming the top of the light at the top of the area to be illuminated.

- Use the adjusting screw to help set the light angle. When angle is found use the lock nut on the adjusting screw to hold it in place while tightening the set screw. Refer to Figure 8.

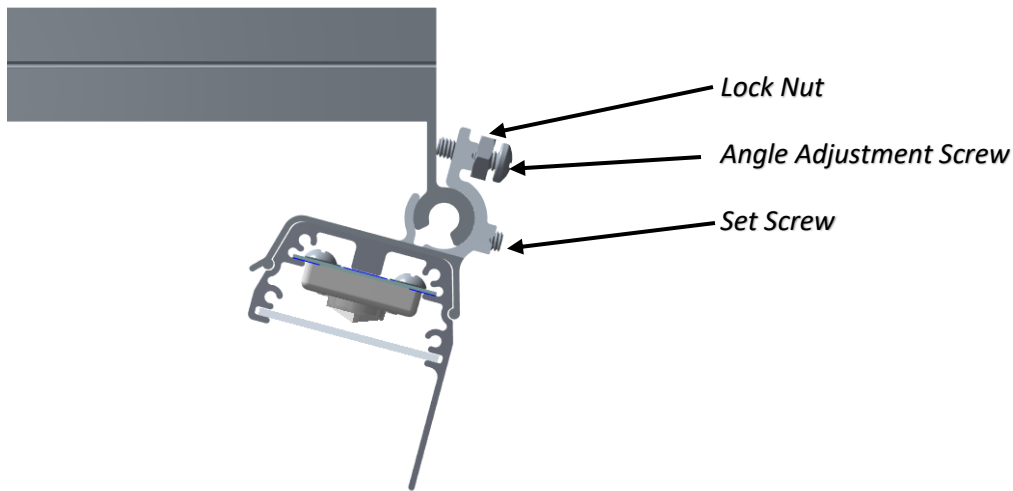

Figure 8 Variable Angle Mount Arm adjustment

LED Driver Loading

The Linear Star LED fixture is powered by the PSH1-1-A-O-X-4 LED driver. Up to 2 power sources can be wired to a fixture assembly. The maximum power source loading is as follows:

Power source quantity	Fixture type	Maximum load
1 (left or right end powered)	Linear Star LED luminaire, 3.7W/ft	25 feet
2 (both ends powered)	Linear Star LED luminaire, 3.7W/ft	25 + 25 feet*

*Note: Do not make the power connection at the midpoint of the luminaire when 2 power sources are used.

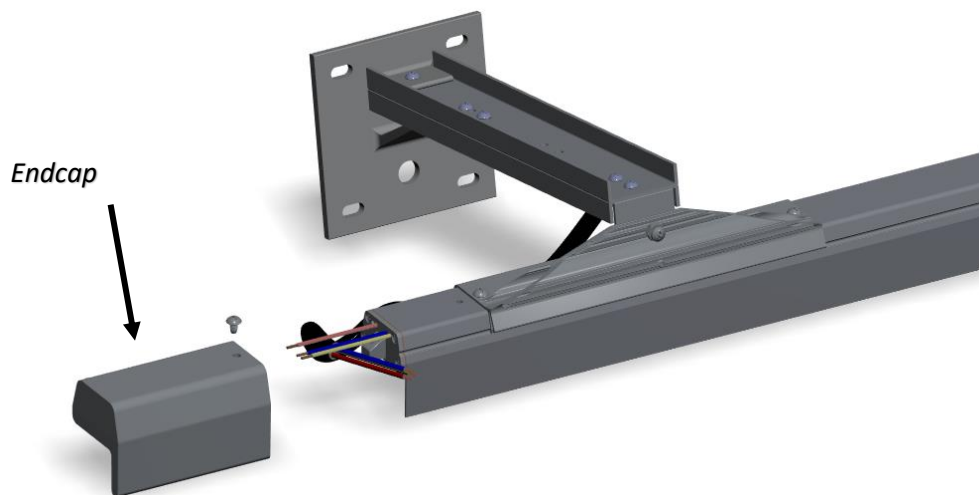
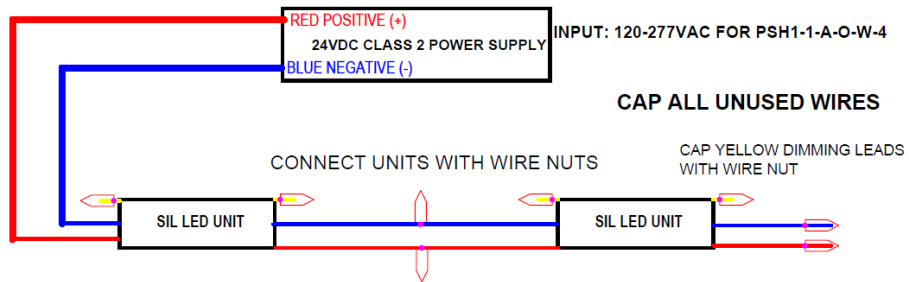

Figure 9: Removal of the endcap



Figure 10: Routing of power cable

LINEARSTAR - WIRING DIAGRAM NON-DIMMABLE



LINEARSTAR DIMMING WIRING DIAGRAM

