

Point XL2 Green Modules

Channel Letter Lighting



Key Features

- Ultra-long life LED modules provide high performance illumination at excellent value.
- Ideal for 2"-12" channel letter depths.

Electrical

- 12VDC input.
- 0-10V dimming available via controller accessory (sold separately).
- Operating temperature: -40°C to 60°C (-40°F to 140°F)

Mounting

- Modules mounted using peel-and-stick 3M VHB tape.

Construction

- Modules are IP67 rated to prevent against penetration of dust and moisture.
- Dimensions: 1.96" x 0.63" x 0.236"

Optics

- Industry-leading Green LEDs (525nm).
- 175° beam angle for ultra-wide light distribution.

Warranty

- Backed by US LED's industry-leading Ten-Year Warranty.

Project	Date
---------	------

Catalog Number	Type
----------------	------

Product Performance Summary

Lumen Output ²	Up to 140 lumens/ft.
Efficacy	Up to 88 LPW
Available CCT	525nm
Warranty	Ten-Year Warranty

Product Overview

Point XL2 is US LED's next generation of channel letter lighting that offers industry-leading performance in a cost-effective solution. Now accommodating even more modules per power supply, Point XL2 provides even greater distribution than ever before for more efficient installations.

Product Applications

- Channel Letter Lighting
- General Sign Lighting

Product Certifications

- UL Recognized (USA/Canada)
- UL Classified for Retrofits (USA/Canada)
- Suitable for Wet Locations
- IP67 Rated



Ordering Information

Example: PXL2-2-12-G

PXL2	<input type="text"/>	<input type="text"/>	<input type="text"/>
Series	# of LEDs Per Module	Voltage	CCT
2	2 LEDs	12 12VDC	G Green

PXL2 Accessories (Sold Separately)

Part Number	Description
PSB-1-12-12	US LED Power Supply 12V 12W
PSB-1-12-60	US LED Power Supply 12V 60W
PS2-1-NA	Life Extender Power Supply Enclosure Natural Galvanized
DCA-10-120	0-10V Dimming Controller 120W RoHS Mark VII
WCC-2-50	Wire Management Clips 50 Qty.

Point XL2 Green Modules

Channel Letter Lighting

Performance Data

Model #	CCT	System Level Power ¹	Delivered Lumens ²	Typical Stroke ³	Efficacy
PXL2-2-12-G	525nm	1.6W/ft.	140 lumens/ft.	12"	88 LPW

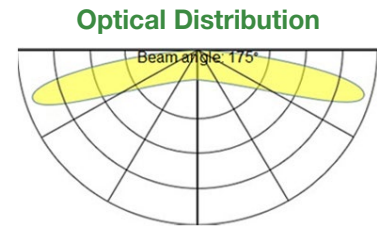

Spacing Chart

	BEST USAGE											
Distance From Face	12"	11"	10"	9"	8"	7"	6"	5"	4"	3"	2"	
Single Row Spacing	12"	12"	12"	12"	12"	12"	12"	12"	10"	8"	4"	
Multiple Row Spacing	12"	12"	12"	12"	12"	12"	12"	12"	10"	8"	4"	
Module-To-Module Spacing	7"	7"	7"	7"	7"	7"	7"	7"	5"	5"	3"	

Packaging Specifications

Packages	# Modules Per Package
Bag	60 Modules
Inner Case	420 Modules (7 Bags)
Master Case	1,260 Modules (21 Bags)
Pallet	52,920 Modules

Power Supply & Loading Specifications

	Series	Minimum # of Modules	Maximum # of Modules
PSB-1-12-12	12W Load	4 Qty.	11 Qty.
PSB-1-12-60	60W Load	6 Qty.	58 Qty.

1. System power consumption, which includes power supply losses.
 2. Estimated light output under application operating conditions.
 3. For 5" depth sign.

Point XL2 Green Modules

Channel Letter Lighting

Accessories

PSB-1-12-12 US LED 12V/12W Power Supply

Overview

The PSB 12V/12W is a high-performance, Class 2 power supply unit intended for use with LED lighting in outdoor signage applications. It is designed to withstand moisture and other outdoor elements with an IP65 rating and is RoHS compliant. The PSB is engineered to speed up installation and ensure reliable operation long term.



Key Features

- For use in outdoor signage applications
- 12VDC, Class 2 power supply
- 90-305VAC input voltage
- Complies with UL 879, UL 8750, UL 1310 and CSA 22.2
- Complies with FCC 47CFR Part 15
- IP65 rated housing



Electrical

- Input voltage: 90-305VAC (120V/0.18A), (277V/0.6A)
- Output voltage: 12VDC
- Output current: 1.0A max
- Output power: 12W max
- Operating temperature: -30°C to +50°C (-30°F to +122°F)

Construction

- Weight: 0.25 lbs. (0.12kg)
- 50 ct. package quantity
- Housing designed for high thermal capability

Dimensions

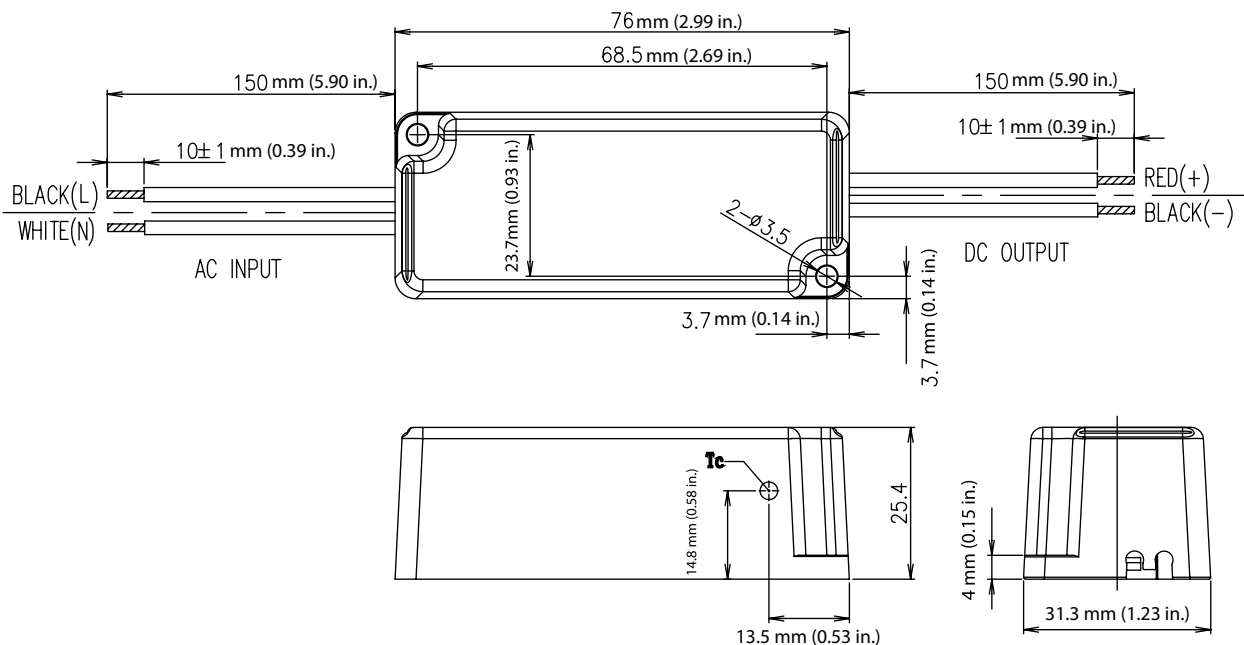

Point XL2 Green Modules

Channel Letter Lighting

Accessories

PSB-1-12-60 US LED 12V/60W Power Supply

Overview

The PSB 12V is a high-performance, Class 2 power supply unit intended for use with LED lighting in outdoor signage applications. It is designed to withstand moisture with an IP66 environmental rating and is RoHS compliant. The PSB is engineered to speed up installation and ensure reliable operation long term.



Key Features

- For use in outdoor signage applications
- 12VDC, Class 2 power supply
- 90-305VAC input voltage
- Complies with UL 879, UL 8750, UL 1310 and CSA 22.2
- Complies with FCC 47CFR Part 15
- Same loading as prior model PSA-12-60
- IP66 rated housing



Electrical

- Input voltage: 90-305VAC (120V/1.05A), (230V/0.56A), (277V/0.50A)
- Output voltage: 24VDC
- Output current: 4.0A
- Output power: 100W max
- Operating temperature: -30°C to +50°C (-30°F to +122°F)

Construction

- Weight: 1.5 lbs. (0.68kg)
- 10 ct. package quantity
- Housing designed for high thermal capability

Dimensions

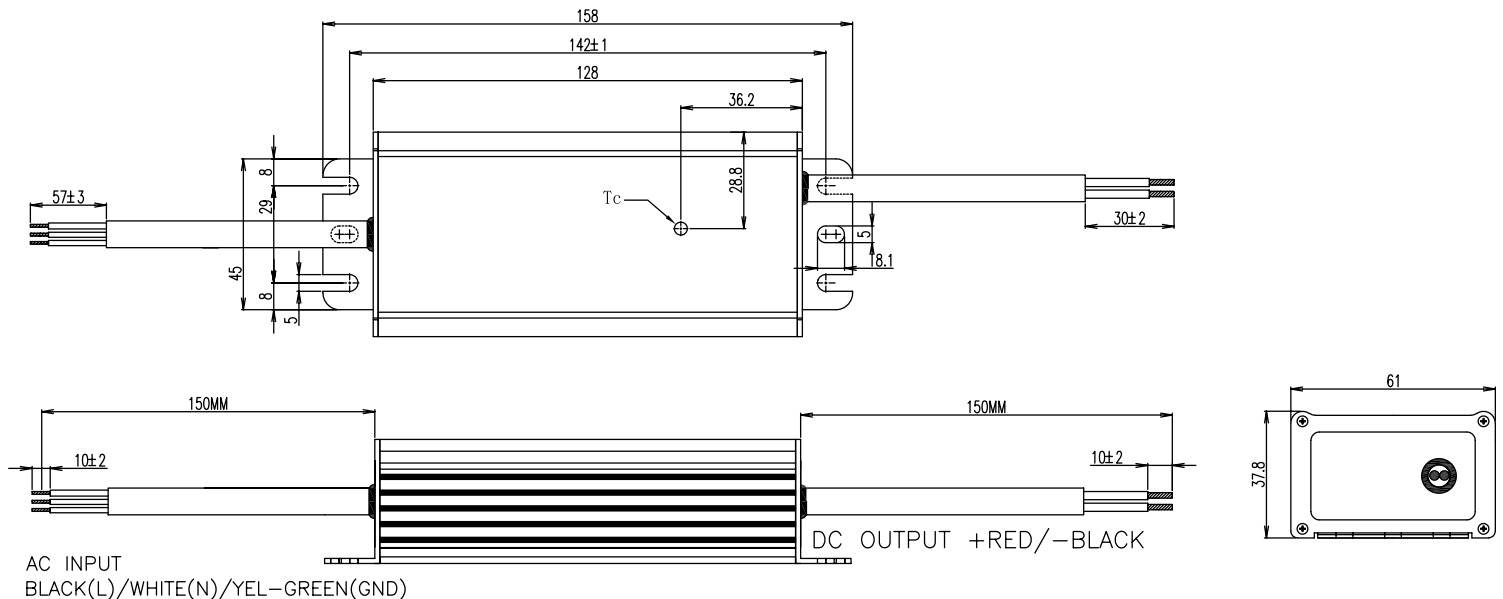

Point XL2 Green Modules

Channel Letter Lighting

Accessories

PS2-1-WT Life Extender Power Supply Enclosure | White

PS2-1-BK Life Extender Power Supply Enclosure | Black

PS2-1-NA Life Extender Power Supply Enclosure | Natural Galvanized

Overview

The PS2 is a multi-purpose power source Box used in LED lighting ranging from signage to commercial and industrial applications. The PS2 is designed to simplify installation of LED drivers and wire connections, all enclosed within one box. It's available as a UL Listed enclosure or as a junction box and LED driver combo. The enclosure is designed for indoor (dry/damp) locations and meets electrical code requirements. It has knockouts on both sides of the enclosure to accommodate all of the input and output connections.

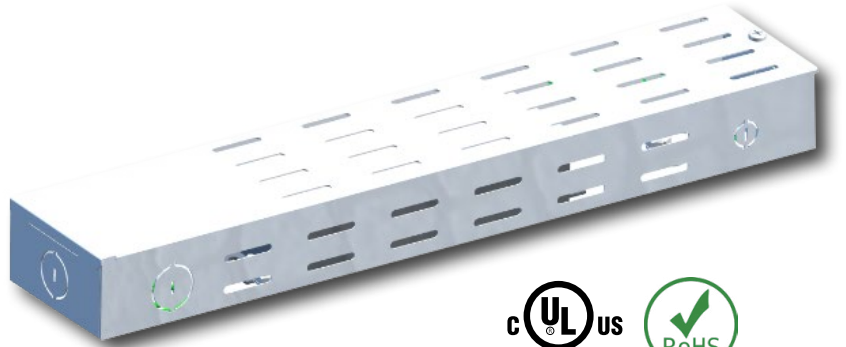

Key Features

- Engineered for use with signage lighting, commercial lighting, and industrial lighting applications.
- Available as a UL Listed enclosure or as a junction box and LED driver combo.
- Suitable for air handling spaces.
- Complies with UL 879, UL 8750, UL 1310, and CSA 22.2
- Rated for indoor (dry/damp) locations.

Construction

- Robust 24-gauge steel housing protects components from harsh environments.
- Ventilation on three sides of the enclosure optimize thermal management.
- Housing is protected by a corrosion resistant powder coat finish.
- Dimensions: 15 in. X 3 in. X 1.63 in.
- Weight: 1.30 lbs.

Mounting

- Suitable for cabinet or surface mounting use.
- Consult factory for additional mounting options.

Dimensions

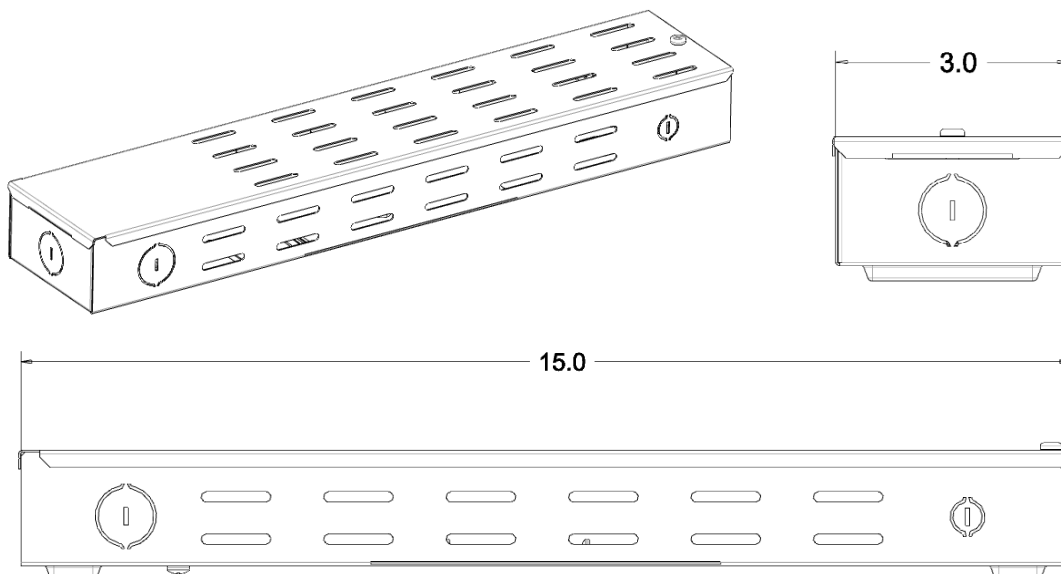

Point XL2 Green Modules

Channel Letter Lighting

Accessories

WWC-2-50 Wire Management Clips (50 Qty.)

Overview

The wire management clip helps to guide wiring around equipment and cabinets. This C-type clip has adhesive backing that allows mounting virtually to any clean, dry surfaces without drilling. The wire management clip prevents wires from blocking light, especially in shallow channel letters.

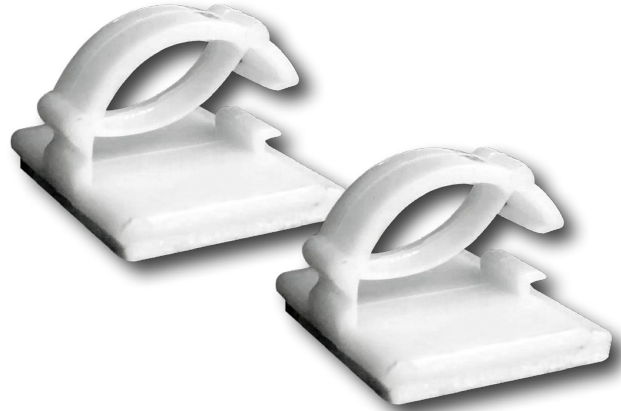

Key Features

- C-type clip designed to assist with wire management for sign cabinet and channel letter installations.
- Suitable for damp locations.

Construction

- Constructed from nylon 6/6 material.
- White color finish.
- Dimensions: 0.75 in. X 0.75 in. X 0.37 in.
- Slot dimensions: 0.23 in. x 0.19 in.

Mounting

- Adhesive backing for mounting to dry, clean surfaces without drilling.